

REV 更改号	DATE 日期	REVISION DETAILS 更改内容	APPD 审核并批准
A	Jul.02,2019	Drawing Update	
B	May.19,2021	Add a bore Dia. $\varnothing 5.15 \pm 0.08$	<i>[Signature]</i>

Change the undercut Dia. to 9.14 ± 0.13

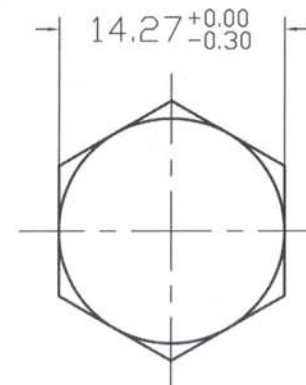
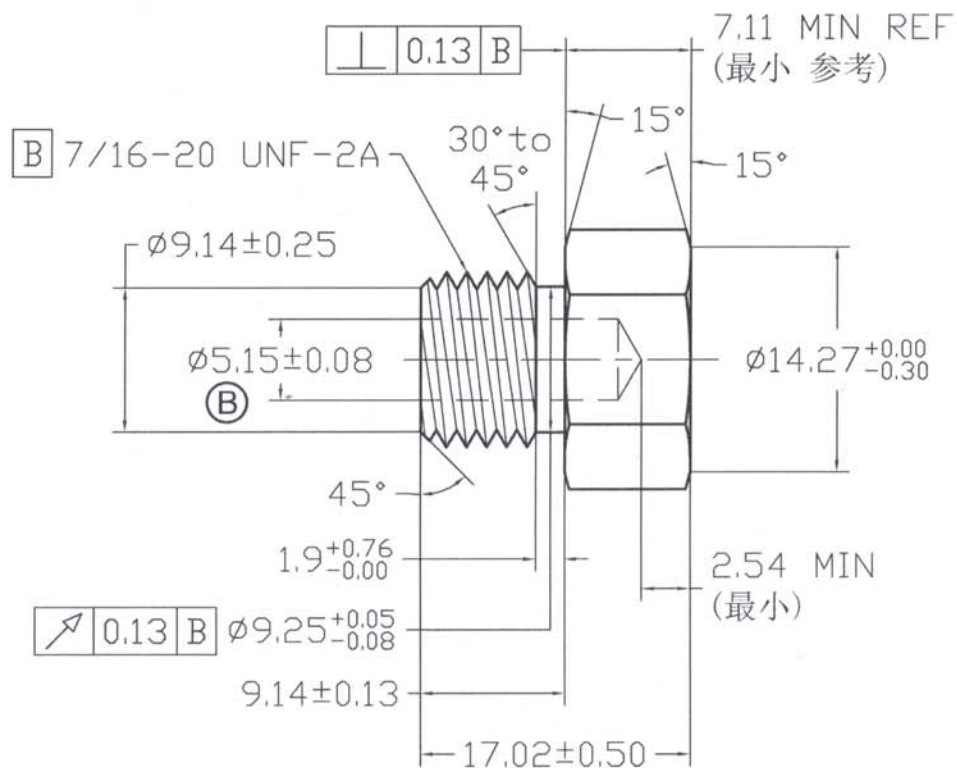

UNLESS SPECIFIED
ALL DIMENSIONS ARE IN mm,
ROUGHNESS ON
HEXAGON SURFACE ∇
MACHINED SURFACE $R_a=3.2\mu m$,
ANGLES TOLERANCE $\pm 5^\circ$,
DIMENSIONS TOLERANCE $\pm 0.25mm$,
REMOVE ALL BURRS, SLIVERS AND
SWARF,
BREAK ALL SHARP EDGES $R<0.5mm$

其它事项,
图示尺寸单位为mm,
六角面粗糙度 ∇
未注机加工表面粗糙度 $R_a=3.2\mu m$,
未注角度公差 $\pm 5^\circ$,
未注尺寸公差 $\pm 0.25mm$,
去除所有毛刺及金属切屑,
锐边倒钝 $R<0.5mm$.

Zhejiang Gaocheng Autoparts Co.,Ltd	
 THIRD ANGLE PROJECTION	PART No 零件名 6408-4 PLUG
SCALE: NTS	APPD: 批准 <i>[Signature]</i> DATE: 日期 19/5/21 DRN: Pan 制图 2019.07.02 CHK: Pan 审核 2019.07.02

MATERIAL	Chinese steel 45	材料 45号钢
FINISH	ZINC PLATING WITH 8um MICRONS MINIMUM PLATING THICKNESS AND TRIVALENT CHROMATE PASSIVATION AND WITHSTAND 96 HRS TO WHITE / 144 HRS TO RED RUST IN SALT SPRAY TEST.	镀锌, 三价铬钝化, 银白色, 能零试验96小时无白斑, 144小时无红锈, 镀锌层厚度大于8um.